

NT33 - 2AF3-KJA76M8-CBA

Product Specifications



Product Specifications

NT33-2AF3-KJA76M8-CBA

Product Features

- **Motor type:** 2 motors / High-power motor
- **Post type:** 2- legged , 3- section rectangular upright / without holes
- **Post dimensions:** 70x40/75x45/ 80x50 mm
- **Table height adjustment range :** 600-1250 mm
- **Column travel :** 500mm
- **Frame telescopic range :** 1010-1750 ± 5 mm
- **Compatible desktop length range :** 1200-1800 mm
- **Side panel length:** 575mm
- **Foot size :** 700 x 75 mm
- **Maximum load capacity of the entire table :** 160kgs/353lbs
- **most big speed Speed :** 50mm / s
- **Low noise sound water Level:** No-load ≤50dB
- **Functions:** Obstacle detection and backtracking safety protection / sedentary reminder, etc.
- **treat machine achievement Consumption :** < 0.1W
- **surface** **Surface : Powder coated**
 White (standard color)
 Black (standard color)
 Gray (standard color)
- **Bag Pack ruler Size :** 1065*270*215
- **Gross / Net Weight:** 28/26kgs



Optional

- Custom colors are acceptable.
- Compatible hand controller models or series: standard hand controllers
- Compatible controller models or series: standard controllers
- Available with various types of feet

How to use

- **Work schedule:** 10%; 2 minutes of work followed by an 18-minute break.
- **Usage environment:** Indoor
- **Storage and transportation temperature:** -10°C ~ 70°C

Dimensions

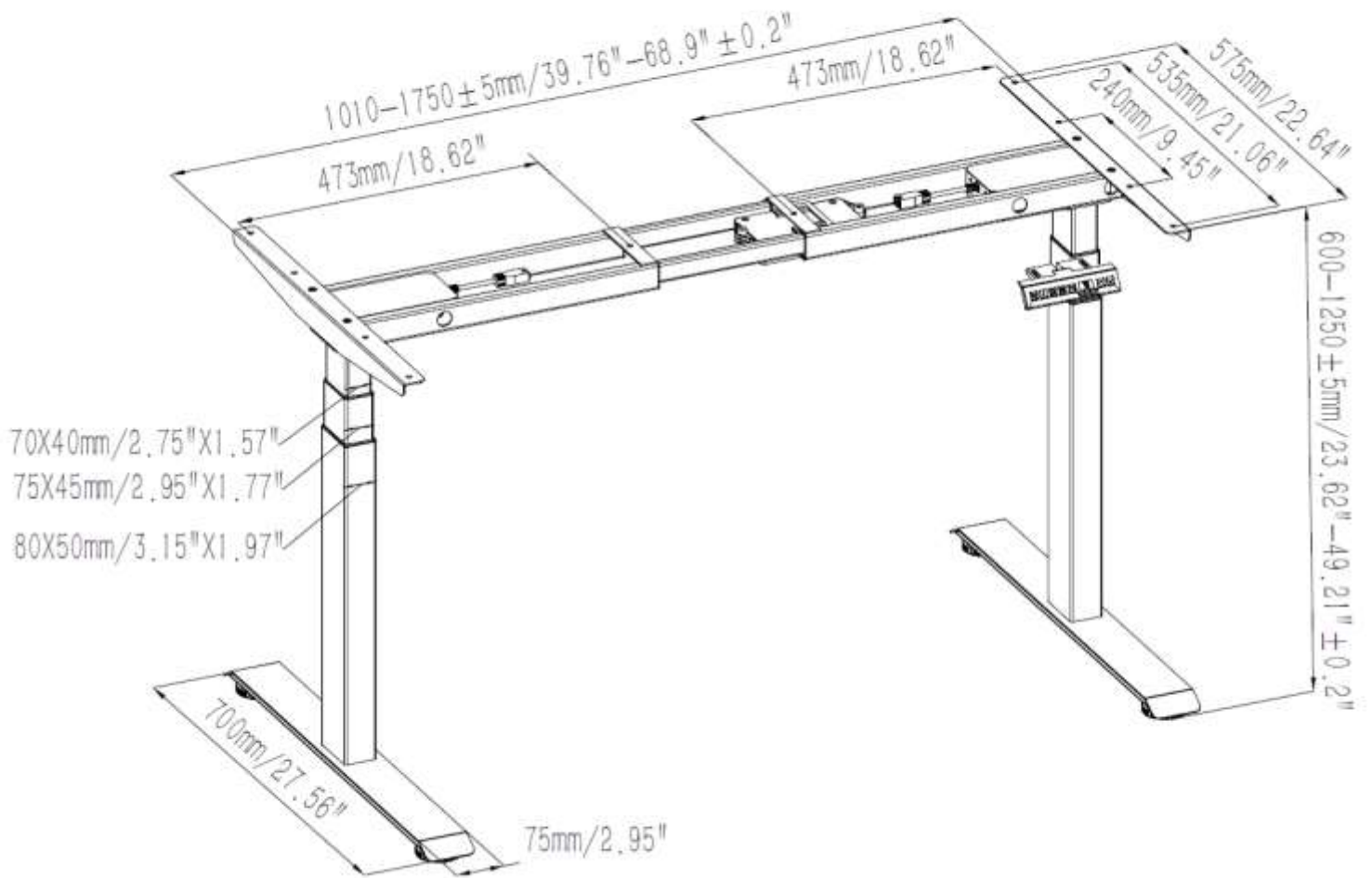

Naming rule

example

NT33 X - X - X - X - X - X - X - X

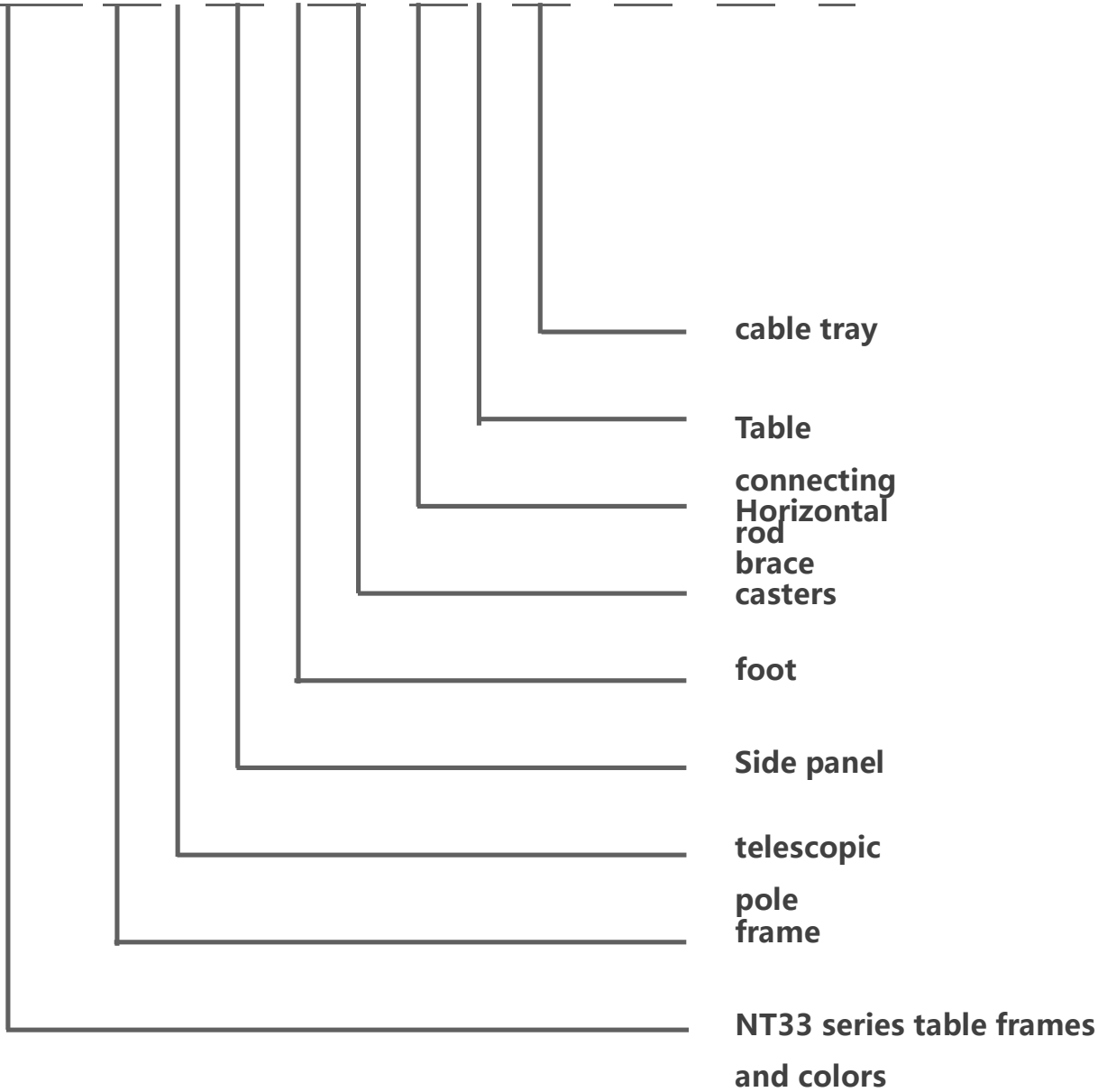

F represents no hole / A represents standard installation / R represents inverted installation / G represents ball bearing.